



UPTIME VRU

10HP -150HP Electric Packages

The Perfect Solution for
Natural Gas Emissions
& Artificial Gas Lift



100%
CAPTURED

0%
TO ATMOSPHERE

High Reliability & Big Returns!

Capturing natural gas emissions from oil field stock tanks has never been this easy and financially rewarding!

By meeting all of the Environmental Protection Agency (EPA) regulations, you are not only capturing the illegal Volatile Organic Compounds (VOC's), but you are also able to re-sell the captured gases allowing the Vapor Recovery Unit (VRU) to pay for itself! Featuring our automated precision monitored control system with integrated blanket gas management, these VRU's are suited to accommodate the tight control needed to maintain the low pressure range of vapor recovery.

- Low Maintenance
- Designed to Run Unattended
- Very Effective for Handling Wet Gas
- Electric Motor Driven (Class 1 Division 2 Group D)
- Smooth and Quiet Operation
- No Special Foundation Required
- Electric Motor
- Single Stage, Rotary Screw Compressor
- Stainless Steel Hoses / Tubing
- Full Flow Compressor Oil Filter
- Compressor Oil Thermal By-Pass Valve
- Compressor Separation Receiver Tank
- Inlet Gas Scrubber/Blowcase with Filter Element & Auto Dump System
- Compressor Oil Cooler / After Cooler
- Heavy Duty Skid Frame with Environmental Containment Pan
- Rust Resistant Electrostatic Powder Coat Finish



UPTIME
GAS RECOVERY SYSTEMS

(10-75 HP DIMENSIONS)

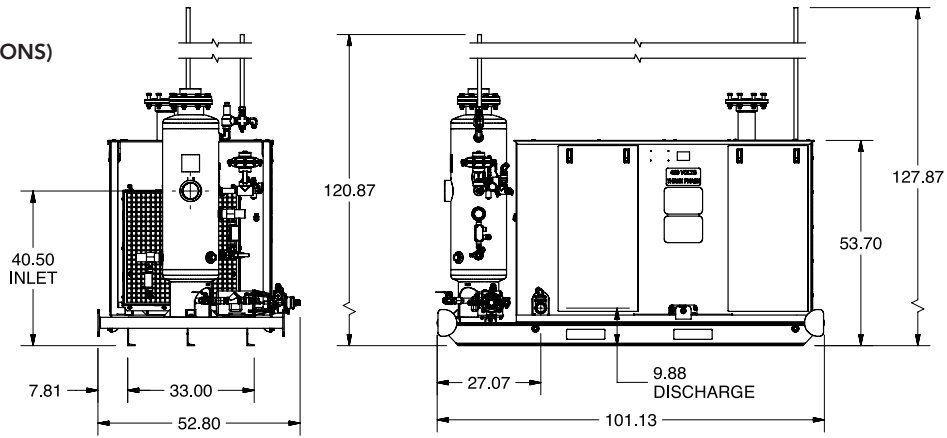

COMPRESSOR DATA						
MODEL	10-7D	20-8D	30-8G	50-10D	60-10G	75-14G
CAPACITY @ 0 PSI SUCTION	20MSCFD	40MSCFD	75MSCFD	110MSCFD	190MSCFD	240MSCFD
MOTOR	10HP	20HP	30HP	50HP	60HP	75HP
INLET NPT	4"	4"	4"	4"	4"	4"
DISCHARGE NPT	2"	2"	2"	2"	2"	2"
WEIGHT	2,200LBS	2,300LBS	2,400LBS	2,800LBS	2,950LBS	3,200LBS

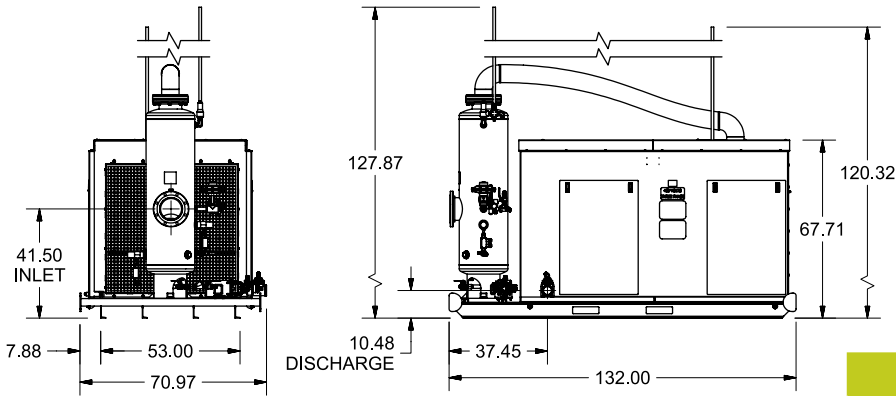

(150 HP DIMENSIONS)

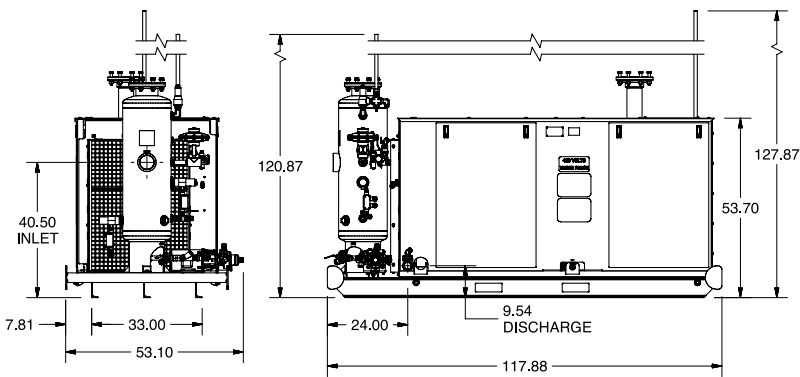

(100 HP DIMENSIONS)

COMPRESSOR DATA			
MODEL	100-14D	150-14G	150-14G ME
CAPACITY @ 0 PSI SUCTION	500MSCFD	650MSCFD	400MSCFD
CAPACITY @ 50 PSI SUCTION	N/A	N/A	1.5MMSCFD
MOTOR	100HP	150HP	150HP
INLET NPT	4"	8" FLANGE	8" FLANGE
DISCHARGE NPT	2"	3"	3"
WEIGHT	4,200LBS	6,500LBS	6,700LBS



3908 Cane Run Road
Louisville, KY 40211
Voice: 502-500-6115

Email: dnusbaum@uptimegasrecovery.com